



Fines Recovery Equipment

Fine Material Processing SOLUTIONS

Fractionators

Dewatering Screens

High Rate Thickeners

Vertical Durability Cells

Quad Attrition Mills

Super Cutter Hydro-cyclones



DESIGN



FABRICATION



INSTALLATION



MAINTENANCE

THIS IS WHAT WE DO

1762 W Grant Road
Tucson, AZ 85745

(520) 572-7239

contact@azfab.com

www.azfab.com

PROCESS DESIGN

At AZFAB, we take a different approach to plant design

Our professional service literally starts from the ground up with testing and analysis of your material samples. Next, we make sure we thoroughly understand your site. We'll examine your water reserves, ponds, wells, existing equipment, mining plans and market requirements. Before we design a solution, we'll find out what YOU want to achieve. In fact, you may already have viable components in place, and only need key changes in your process to move your operation from marginal to very successful. AZFAB knows one-size does not "fit all," and our design will be uniquely tailored to your operation.



AZFAB Dewatering Screens produce finished product with moisture content of just 10 to 15 percent, with some plants achieving an even drier product. Each system is custom designed to match your plant and operational needs for the specific environment.

DEWATERING SCREENS



The Dewatering Screen is designed to replace or enhance sand screws and deliver a dryer, cleaner fine aggregate product.

- Material discharges at 10-15% moisture content, creating a dry, stackable products capable of being transported via conveyor
- A pair of counter-rotating vibratory motors provide the linear motion to move material up an inclined dewatering deck
- AZFAB Dewatering Screens capacity is based on well graded C-33 concrete sand. Capacity decreases as particle size diminishes.
- Screens range from 2 to 7 feet in width and handle up to 350 tons per hour.

DESIGN ▶ FABRICATE ▶ INSTALL ▶ MAINTAIN

PROCESSING SOLUTIONS

T H I S I S W H A T W E D O

FRACTIONATORS



AZFAB Fractionators are a solution for the customer who needs a coarser cut than a cyclone, but not the complexity of a classifying tank. Our fractionators are adjustable to make a variety of separations by controlling rising rate in a teetered bed. These machines are fully automated and feature a modulating valve to meter the underflow, as well as replaceable spray bars, fed from a wraparound manifold, to provide a consistent rising current.

The Fractionator is a single station rising current classifier. The rising current makes sharp cuts in fine sands to produce a desired size classification or gravity separation.

- Capable of accurately classifying materials between # 40 - # 100 mesh
- Fractionator underflow valve is PLC driven based on internal teetered bed depth
- Sizes ranging from 6' to 12' capable of handling up to 300 tons per hour of Sand
- Fully automated and urethane lined for durability

AZFAB Fractionators are manufactured in six different models. For more detailed information contact a sales representative at 866.616.9351.



HIGH RATE THICKENERS



AZFAB High Rate Thickeners can significantly reduce the size of your settling ponds with minimal power consumption and chemical cost. Plant effluent is thickened with polymer dosing. Rake arms pull the mud to the center cone where it is evacuated and sent to further processing or a holding pond.

The Thickener – Clarifier recycles water by separating the liquid from the solids. Thickener concentrates the sand, and clarifies the water.

- Recycle on average 92% of the water used in a wet plant making it immediately available for re-use
- Making efficient use of flocculants
- Reduce the size or eliminate the need for settling ponds
- Minimal power consumption and chemical cost
- Only moving part is the hydraulic rake assembly
- Sizes available ranging from the 20 ft. thru 85 ft. in diameter
- Ability to handle up to 230 tons per hour and 17,500 gallons per minute

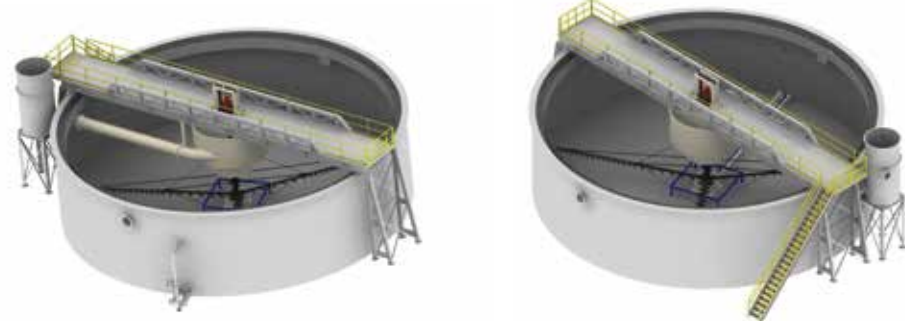

VERTICAL DURABILITY CELLS



AZFAB Vertical Durability Cell provides the scrubbing power necessary to liberate clays. Our system employs an aggressive new design that causes the incoming particles to abrade against each other, liberating small clay residuals.

- Paddles inside the Vertical Durability Cell provide the force to scrub the sand and liberate clay particles
- Completely lined with ½ inch 40 durometer natural rubber
- Optional control system with variable speed drives
- Two sizes:
 - Single Shaft 125 tons per hour – 90-second retention time
 - Twin Shaft 225 tons per hour – 90-second retention time
- Capacity varies with designed retention time

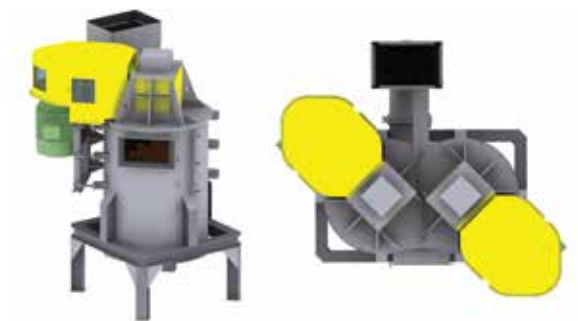

QUAD ATTRITION MILL

The AZFAB Attrition Mill design was planned with our customer's needs in mind.

- Process UP TO 300TPH
- Maximize retention time to allow for best possible scrub
- Easily serviceable modules for optimal uptime
- Modular paddle shaft design with replaceable blades
- Removable internal rubber coated wear liners
- Self contained auto lubricating gear boxes
- Top mounted inspection ports

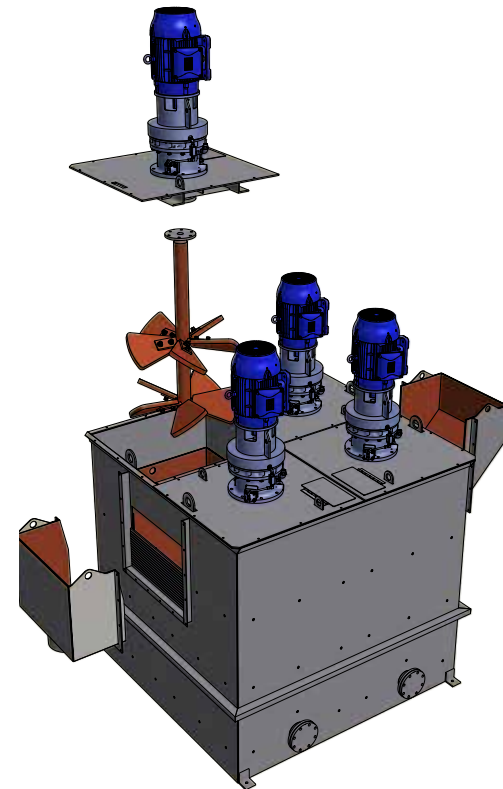
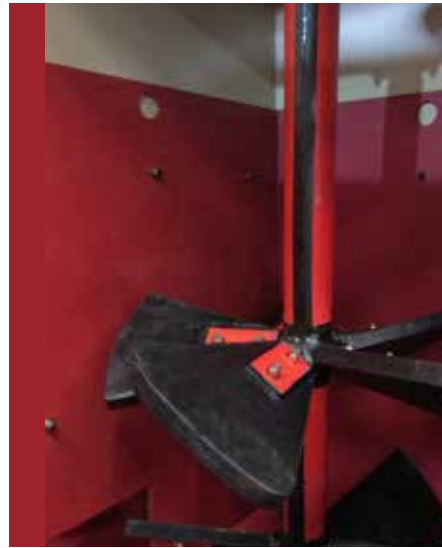

SUPER CUTTER HYDRO-CYCLONES

The AZFAB Super Cutter Hydro-Cyclone uses centrifugal force alone to separate material by size and density. The cyclonic action inside the steel fabricated body forces material to separate with heavy particles falling to the bottom while the fine light material is pulled through the overflow.

- All steel construction
- No moving parts
- Vertical cylinder with a conical bottom section
- Internal lining of ½' thick 40 durometer natural rubber
- Operates with 8-10 psi inlet pressure
- Extended Body Super Cutters are available to provide finer cuts in the material
- Five different sizes of Super Cutters (gallons per minute/tons per hour)
 - 400/30
 - 900/70
 - 1200/90
 - 2000/150
 - 3000/225
- Operate anywhere from 0-100% of rated feed tons per hour





Fines Recovery Equipment



THIS IS WHAT WE DO



DESIGN



FABRICATION



INSTALLATION



MAINTENANCE

 1762 W Grant Road
Tucson, AZ 85745

 (520) 572-7239

 contact@azfab.com

 www.azfab.com



ASSEMBLED IN THE USA